

Series 2000SS

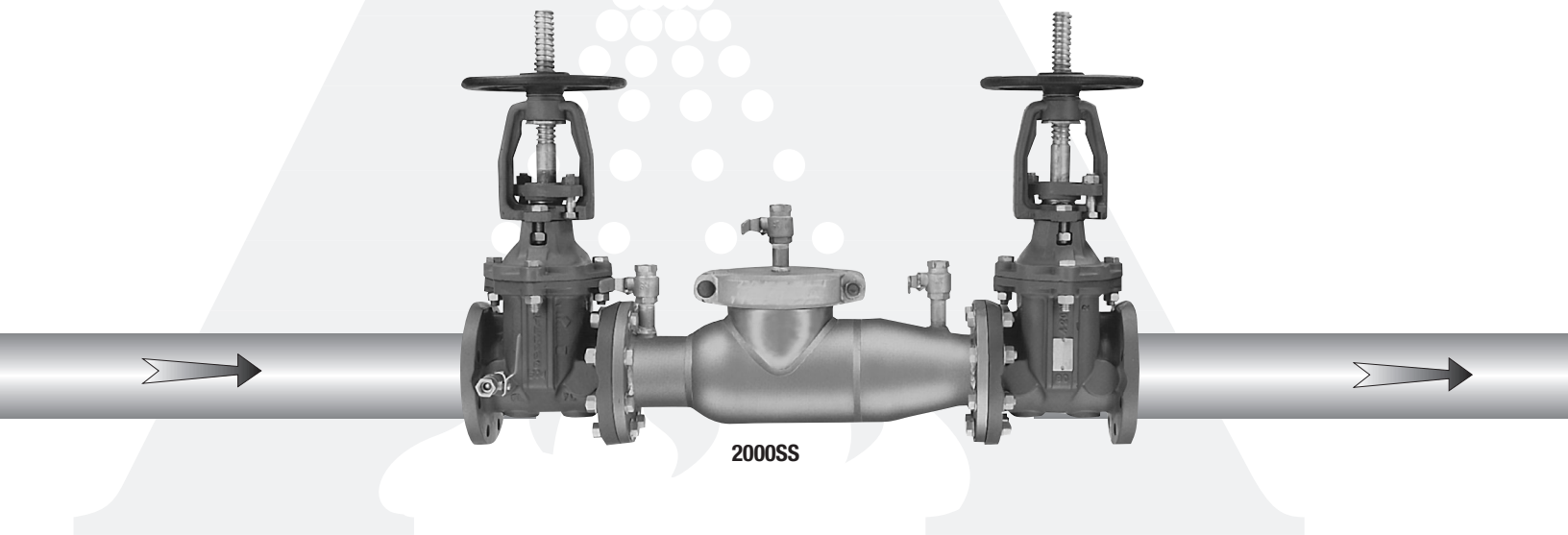

Double Check Valve Assemblies & Double Check Detector Assemblies

Sizes: 2¹/₂" – 6"SS (65 – 150mm)

- Installation
- Service
- Repair Kits
- Maintenance

IMPORTANT: Inquire with governing authorities for local installation requirements.

NOTE: For Australia and New Zealand, line strainers should be installed between the upstream shutoff valve and the inlet of the backflow preventer.

It's important that this assembly be tested periodically in compliance with local codes, but at least once per year or more as service conditions warrant. If installed on a fire sprinkler system, all mechanical checks, such as alarm checks and backflow preventers, should be flow tested and inspected internally in accordance with NFPA 13 and NFPA 25.

Limited Warranty: Ames Fire & Waterworks (the "Company") warrants each product to be free from defects in material and workmanship under normal usage for a period of one year from the date of original shipment. In the event of such defects within the warranty period, the Company will, at its option, replace or recondition the product without charge.

THE WARRANTY SET FORTH HEREIN IS GIVEN EXPRESSLY AND IS THE ONLY WARRANTY GIVEN BY THE COMPANY WITH RESPECT TO THE PRODUCT. THE COMPANY MAKES NO OTHER WARRANTIES, EXPRESS OR IMPLIED. THE COMPANY HEREBY SPECIFICALLY DISCLAIMS ALL OTHER WARRANTIES, EXPRESS OR IMPLIED, INCLUDING BUT NOT LIMITED TO THE IMPLIED WARRANTIES OF MERCHANTABILITY AND FITNESS FOR A PARTICULAR PURPOSE.

The remedy described in the first paragraph of this warranty shall constitute the sole and exclusive remedy for breach of warranty, and the Company shall not be responsible for any incidental, special or consequential damages, including without limitation, lost profits or the cost of repairing or replacing other property which is damaged if this product does not work properly, other costs resulting from labor charges, delays, vandalism, negligence, fouling caused by foreign material, damage from adverse water conditions, chemical, or any other circumstances over which the Company has no control. This warranty shall be invalidated by any abuse, misuse, misapplication, improper installation or improper maintenance or alteration of the product.

Some States do not allow limitations on how long an implied warranty lasts, and some States do not allow the exclusion or limitation of incidental or consequential damages. Therefore the above limitations may not apply to you. This Limited Warranty gives you specific legal rights, and you may have other rights that vary from State to State. You should consult applicable state laws to determine your rights. **SO FAR AS IS CONSISTENT WITH APPLICABLE STATE LAW, ANY IMPLIED WARRANTIES THAT MAY NOT BE DISCLAIMED, INCLUDING THE IMPLIED WARRANTIES OF MERCHANTABILITY AND FITNESS FOR A PARTICULAR PURPOSE, ARE LIMITED IN DURATION TO ONE YEAR FROM THE DATE OF ORIGINAL SHIPMENT.**



Installation Instructions

Please Read Prior to Installation:

1. Before installing any Ames backflow assembly, flush the line thoroughly to remove all debris, chips and other foreign objects. Failure to do so may make the assembly inoperable.
2. The Ames 2000SS may be placed in any position as long as the flow indicator arrow in the assembly is pointed in the direction of water flow, and the local water authority has approved the installation configuration. ASSE (American Society of Sanitary Engineers) has approved these assemblies for either horizontal or vertical installation.

3. Allow sufficient clearance around the installed assembly to conduct testing, servicing, and inspection. Allow a minimum of 12" from the flood level to the bottom of the assembly.
4. If double check or double check detector assembly is installed in a vault or pit, be sure proper drainage is available. If sufficient drainage is not available a cross-connection may occur.

Attention Installer: After installation, please leave this Instruction Sheet for occupant's information.

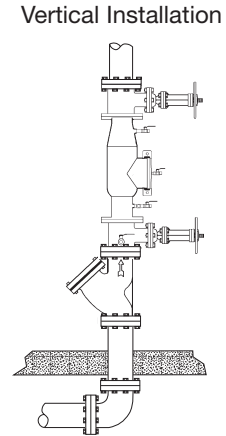
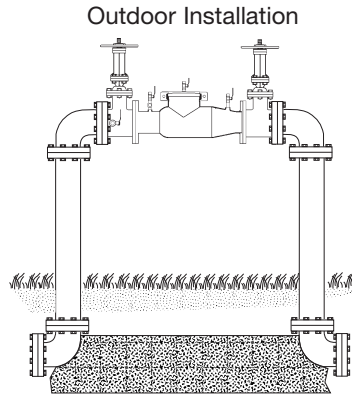
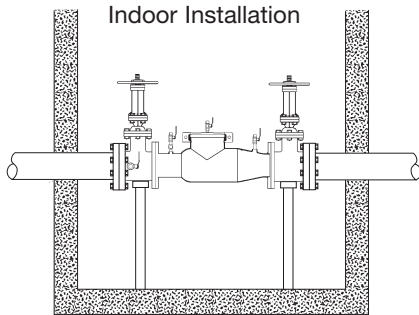

Detailed Parts Listing

Parts Table #1

Item #	Description	Qty	Ames Part No.					
			2 1/2" (65mm)	3" (80mm)	4" (100mm)	6"SS (150mm)	6"SE (150mm)	8"SE (200mm)
1.	#1 Cam-Check	1	7015559	7015559	7015559	7015564	7015559	7015564
2.	#2 Cam-Check	1	7015560	7015560	7015560	7015565	7015560	7015565
3.	#1 Cam-Check O-ring	1	7015333	7015333	7015333	7013280	7015333	7013280
4.	#2 Cam-Check O-ring	1	7013229	7013229	7013229	7013281	7013229	7013281
5.	Cover Plate	1	7013241	7013241	7013241	7013289	7013474	7013289
6.	Ball Valve	2	A000449	A000449	A000449	A000449	A000449	A000449
7.	Groove Coupler	1	7013194	7013194	7013194	7013287	7013194	7013287
8.	Groove Coupler Gasket	1	7013248	7013248	7013248	7013308	7013248	7013308

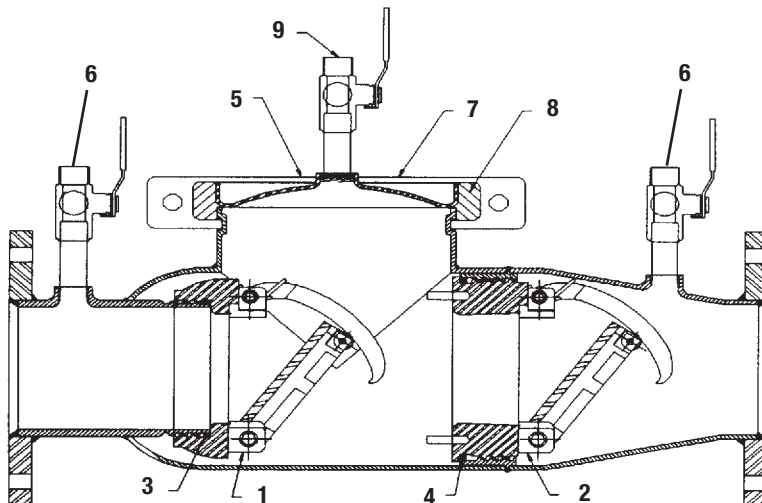

Maintenance Instructions

NOTE: Ames assemblies require minimum maintenance. All assemblies must be retested once maintenance has been performed. Before servicing be certain shutoff valves are closed.

1. Shut down water system and lock out system if possible. Slowly open all ball valves to relieve air and water pressure. Loosen bolts on groove coupler and remove groove coupler and cover plate from valve body.
2. Remove #1 Cam-Check assembly by using your hands to unscrew (turn counter clockwise) Cam-Check and remove through top access port. Do not use Cam Arm as a handle to unscrew Cam-Check. If Cam-Check cannot be loosened by hand, insert a long screwdriver between valve body and Cam-Check (see figure 3). Slowly apply pressure against the Cam-Check until loosened. Finish unscrewing by hand. Unscrew #2 Cam-Check (turn counter clock-wise) by placing a long screwdriver between lugs and applying pressure to loosen #2 Cam-Check. Finish unscrewing by hand.
3. To clean #1 Cam-Check, (except 2½" – 4" (65-100mm) DC check) locate the Cam Arm opening stud on the outlet flange of the valve assembly. Slide the Cam Arm over the stud with the check threads facing downward (figure 1). Tighten ¼" nut on stud to secure cam bar. Slowly pull the assembly outward to open check allowing exposure of the seat and clapper contact area for cleaning. To clean #2 Cam-Check, lift Cam Arm and hold in open position. Raise clapper so that the end of the Cam Arm rests between roller and clapper (figure 2). Thoroughly clean the seat area and clapper sealing surfaces of both Cam-Checks. Rinse Cam-Checks and O-rings thoroughly. Inspect seats, clapper sealing surfaces, Cam Arms, and O-rings for damage. If not damaged, gently close the clapper. If damaged, install a new Cam-Check assembly and/or O-ring.
4. Before reinstallation of Cam-Checks thoroughly clean O-ring groove and lubricate O-ring with FDA approved lubricant. Insert and thread #2 Cam-Check first and then #1 Cam-Check. #2 Cam-Check should be tightened by inserting a long screwdriver between lugs to tighten firmly (see figure 1 on reverse side). Do not over tighten. Tighten #1 Cam-Check firmly by hand only. Replace cover plate, clean groove coupler gasket and groove, replace groove coupler. Close ball valves.

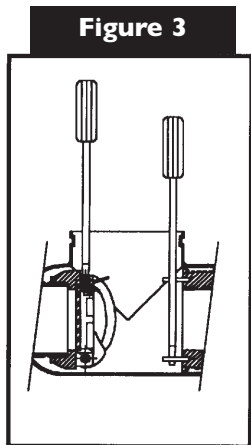

Figure 3

Figure 1
Cam Arm Open Pin

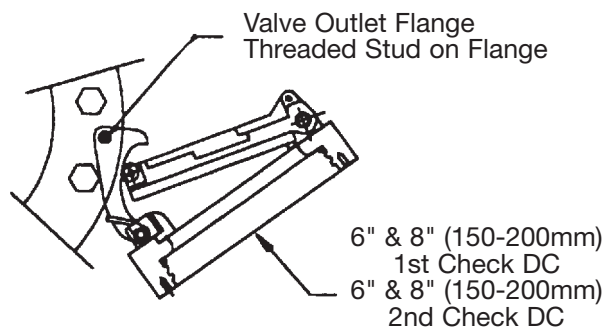
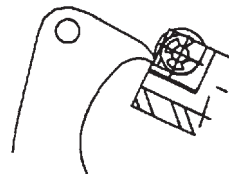
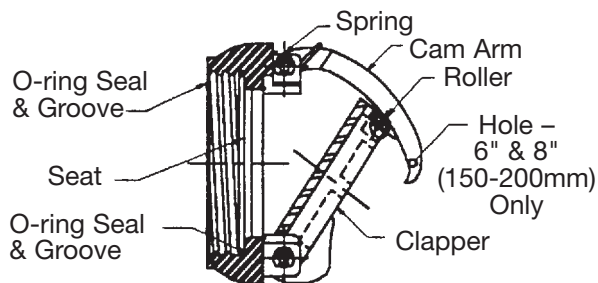

Figure 2
Cleaning Position



#1 Cam-Check 2½" – 6" (65-150mm)



#2 Cam-Check DC & RP

